



**AIRWOLF<sup>3D</sup>**

**AXIOM**

**OPERATION GUIDE**



## LETTER FROM THE MANUFACTURER

---

Thank you for choosing Airwolf 3D and the AXIOM desktop 3D printer. We pride ourselves in providing excellent quality machinery and an overall outstanding user experience. Airwolf 3D is not just another 3D printer company – we are engineers, we are makers, we are designers, we are artists, and most important – we are visionaries.

AXIOM is the most advanced desktop 3D printer in the industry. It is a high-caliber machine capable of extraordinary things – multi-material capabilities, enhanced speeds, fine resolution, and so much more. We have taken everything our customers love about our award-winning HD series and have added the features needed to take desktop 3D printing to a whole new level. You will not find another machine like it.

At Airwolf 3D, we do not see you as just another customer. You are family. You are a member of an elite group of 3D printer operators who have decided to add a high-class machine to their tools. We have added this guide to allow you to get started with the best experience possible, and to give you the instruction needed to push the boundaries of additive manufacturing. Now go create, inspire, design, push the limits — **welcome to the WOLFPACK!**

- *Airwolf 3D Team*

©2016 Wolf and Associates. All rights reserved.

# SAFETY GUIDELINES

## PLEASE READ CAREFULLY BEFORE PRINTER OPERATION

AXIOM is an advanced machine capable of reaching extremely high temperatures and fast speeds. Please be aware of possible hazards when operating.



### BURN HAZARD

The heated bed can reach temperatures of up to 145°C and also generates heat inside the enclosed frame (does not apply to AXIOMe). The hotend reaches temperatures of 315°C. Never touch the heated bed or hotend while hot, and keep in mind they may take up to 20 minutes to fully cool down. Recently extruded plastic can stick to the skin and cause burns if not careful. Always wait until the hotend is completely cool before removing unwanted plastic or debris. The stepper motors can also generate high temperatures and contact with the skin should be avoided.



### FIRE HAZARD

Flammable materials or liquids should never be placed or stored next to the printer.



### ELECTRIC SHOCK HAZARD

The internal electric components can cause electric shock even when the printer is powered down or unplugged. Never open the electronics compartment without consulting your Airwolf 3D technician first.



### MOVING PARTS HAZARD

Never touch moving parts or place your fingers in or on any of the belts, pulleys or gears while the printer is operational. Make sure to tie back long hair and remove any dangling jewelry.

### OTHER SAFETY CONCERNS

**Ventilation:** AXIOM features an enclosed print area, but ventilation is recommended, especially with nylon and polycarbonate.

**Printing unattended:** **IT IS NOT RECOMMENDED TO PRINT UNATTENDED!!!** If you must leave the room where the printer resides, make sure to hook up an external video camera for video monitoring.

**Age:** It is not recommended for children under the age of 18 operate the printer without adult supervision.

**Choking Hazard:** The printer features small parts which can be a choking hazard for young children.

# TABLE OF CONTENTS

---

<b>STEP 1:</b> Unpacking AXIOM 3D Printer and Installing Spool Holder	5
<b>STEP 2:</b> Basic LCD Operation	7
<b>STEP 3:</b> Loading Filament and Priming the Hotend	8
<b>STEP 4:</b> Preparing the Print Surface	10
<b>STEP 5:</b> Auto-Leveling Procedure	11
<b>STEP 6:</b> Running the First Print	12
<b>STEP 7:</b> Removing Parts from the Build Plate	13
<b>STEP 8:</b> 3D Printing Your Custom Parts	14
▪ Configuring APEX Software	14
▪ Configuring and Using Astroprint/ Wireless Printing via Wi-Fi	19
▪ Print via USB with Repetier Host	30
<b>STEP 9:</b> Changing Filament	34
<b>STEP 10:</b> Tips and Tricks	37
<b>STEP 11:</b> Maintenance	39
<b>STEP 12:</b> Troubleshooting	40
<b>WARRANTY INFORMATION</b>	41
<b>TERMS OF USE</b>	42
<b>FILAMENT GUIDE</b>	43
<b>REPLACEMENT PARTS/ ACCESSORIES</b>	44
<b>FILAMENT</b>	45
<b>AXIOM 3D PRINTER DIAGRAM</b>	46

# UNPACKING

## 1 REMOVE PRINTER FROM BOX

Carefully cut the tape on the top of the box and open the lid. Remove the foam piece on top of the printer. With two hands, grab the upper aluminum pieces of the frame, and pull the printer out of the box. Use caution, as the printer is heavy. Locate and remove the accessory box inside the printer.

1. Cut the Zip Ties
2. Remove the tape and stickers from the glass plate.



For more detailed unpacking instructions, view the instructional video at [www.goo.gl/RJTxy](http://www.goo.gl/RJTxy)



## 2 CHECK BOX CONTENTS

After opening the box, locate the following and make sure everything has been included:

- 1 Spool of ABS
- Accessory bag with Power Cable, USB Cable, Wolfbite, RAMBo accessory kit, USB thumb drive, Micro SD Adapter, Spool Holder, Hex Wrench Set
- Micro SD Card (Located in the LCD Controller Slot)
- FLEX-RESISTANT GLASS (Already installed on bed)
- .50 Nozzle
- Drill Bit for Nozzle
- RAMBo/ Wolfbox Cable

## 3 INSTALL POWER CABLE AND POWER ON

In the accessory box, locate the power cable and plug it into the back of the printer. Turn on the printer using the switch located next to the power cable.

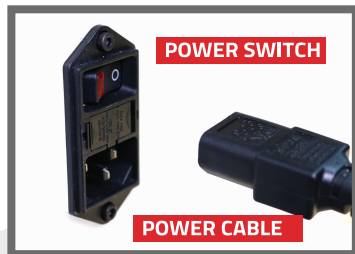

## 4 REMOVE THE BED FOAM

The AXIOM Dual print bed will only raise to -6mm, this will give enough clearance for the foam to be removed. Raise the bed by using the Viki LCD screen. NOTE: Foam is a tight fit and will require some force to pull out. Bed will have full range of motion once the printer has been auto homed.



# UNPACKING

## 5 INSTALLING SPOOL HOLDER

Locate the spool holder and the Teflon tube in the accessories box. Slide the spool holder into the dedicated slot located on the back of the printer. Install the supplied 2.2 lb. spool of ABS filament on to the spool holder. Insert the filament into the tube and continue to push it until it passes completely through the Teflon tube. If the spool and filament is not loaded correctly it will not feed properly, and the filament could jam or break.

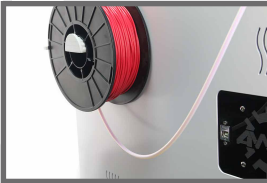
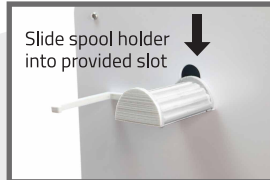
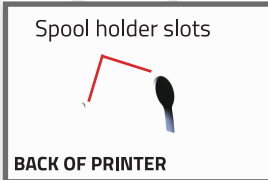

## 6 LOCATE FLEX-RESISTANT GLASS AND BOTTLE OF WOLFBITE

Locate the **FLEX-RESISTANT GLASS** and bottle of Wolfbite in the accessories box and set aside. We will need these in the following steps.



# BASIC LCD OPERATION

**WE WILL USE THE ADVANCED LCD CONTROL SYSTEM TO PERFORM PREHEAT/PRIMING OPERATIONS, LOADING AND UNLOADING FILAMENT, LOWERING/RAISING THE HEATEDBED, AS WELL AS PRINTING FROM THE MICRO SD CARD. DO NOT HAVE THE USB CONNECTED WHILE OPERATING THE LCD SCREEN.**

## 1 MAIN DISPLAY

The main display, or home screen, displays current heatedbed and hotend temperatures, targeted temperatures, print status, XYZ coordinates, and flow rate.



## 2 SECONDARY AND PREPARE MENU

Press the center button on the LCD to enter the secondary menu.

The secondary menu will be used to load/remove/prime filament, preheat the printer (hotend, bed, or both), start a print from the micro SD card (covered in later sections) and manually move a specific axis (i.e. raising or lowering the bed). To scroll through the secondary menu, turn the large wheel surrounding the selection button. When the desired item is highlighted, press the selection button.

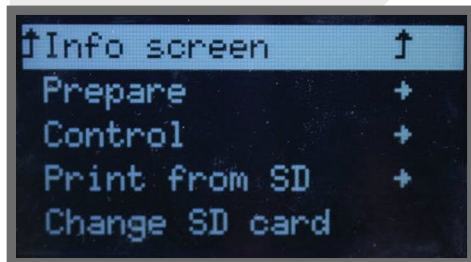

To move a specific axis, enter **PREPARE** and scroll to the bottom of the menu by turning the scroll wheel, then when **MOVE AXIS** is highlighted press the selection button. Choose the distance increment (i.e. 10mm will move the desired axis in 10mm increments when turning the scroll wheel on the LCD.) 10mm can be used for the X and Y axis, whereas 1mm will be used for the Z axis and extruder. To manually move the axis, turn the scroll wheel after you have chosen the desired movement increment.

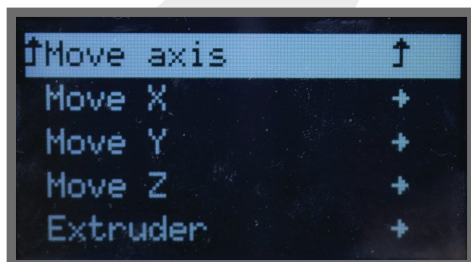

*Note: Use the **MOVE AXIS** command on the **Z AXIS** to move the bed up and remove the foam from underneath.*

## BASIC LCD OPERATION

In case you must pause (i.e. filament change) or stop a print, you can enter the **SECONDARY MENU** by pressing the select button during printing. Using the scroll wheel, select either pause or stop. Pause will allow you to stop a print, then resume where the print left off. This must be done quickly as resuming too late can cause a failure. Stopping a print will cancel a print, but will leave the hotend and heatbed heaters on. **IT IS RECOMMENDED TO POWER OFF THE PRINTER IF NOT PLANNING TO START ANOTHER PRINT.**

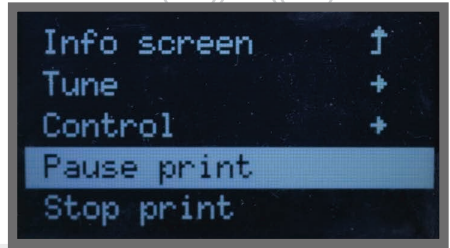

See **STEP 2** on **PAGE 7** for directions on how to change filament when the machine is paused.

**DEPENDING ON WHICH TYPE OF EXTRUDER IS ON YOUR PRINTER, INSTRUCTIONS ARE BELOW.**

## BOWDEN TUBE LOADING AND PRIMING FILAMENT

### 1 PREHEAT AXIOM

In the **SECONDARY MENU** choose **PREPARE**, then **PREHEAT ABS**, then select **PREHEAT 1**. This will preheat both the hotend and heatbed (**heatbed does not apply to AXIOMe**) to ABS printing temperatures. While AXIOM is preheating, use a pair of wire cutters to cut the tip of the ABS filament at an angle. This will help insertion into the easy-feed extruder.

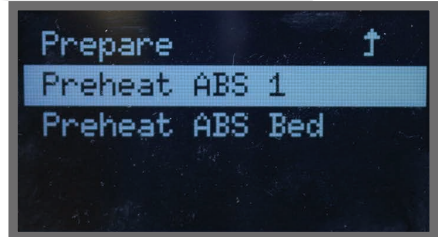

### 2 LOADING, PRIMING, AND REMOVING FILAMENT.

Enter the **SECONDARY MENU**-> **PREPARE**, then select **LOAD FILAMENT**. AXIOM will allow you 5 seconds to then insert the tip of the ABS filament into the **extruder**. Apply some pressure to the filament until you feel the **extruder** grab and feed the material into the bowden tube. If for some reason the filament did not enter the hotend, select the **PRIME FILAMENT** command to extrude 50mm of material. To remove filament, select the **REMOVE FILAMENT** command.

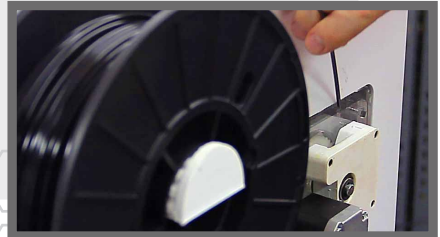
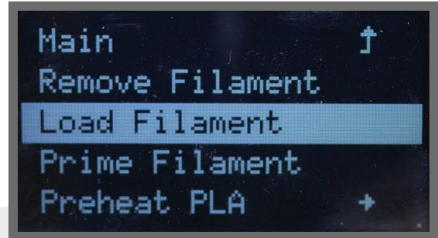

See **TIPS AND TRICKS** on **page 37**-> **LOADING FILAMENT** if for some reason the filament is still having trouble getting into the hotend.

**TO ENSURE LONG LIFE OF THE HOTEND, AXIOM WILL NOT ALLOW YOU TO PERFORM FILAMENT LOADING, PRIMING, AND REMOVAL OPERATIONS IF THE MACHINE HAS NOT BEEN PREHEATED FIRST.**

## DIRECT DRIVE LOADING AND PRIMING FILAMENT

On the **Direct Drive Hot End** pull the latch to the right and up (1), then swing the lower arm down (2). Load the filament in to the Hot End, push down until the filament comes out of the nozzle (3). Close the lower arm (4), and secure the latch (5), you are now ready to print (6).

**DD**  
**DIRECT DRIVE**

1

Welcome to your Airwolf3D Printer



Thank you for your purchase of an Airwolf3D printer. Follow these quick steps to set up your printer and get printing!

Begin Setup

2

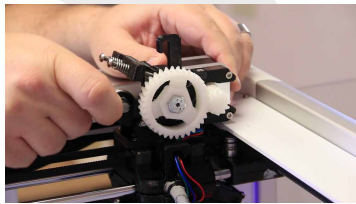

3

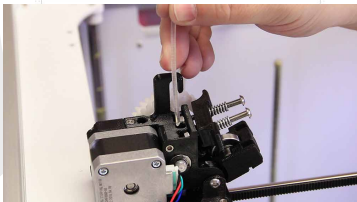

4

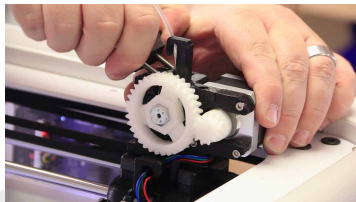

5

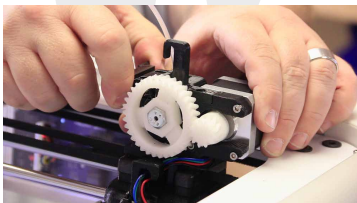

6

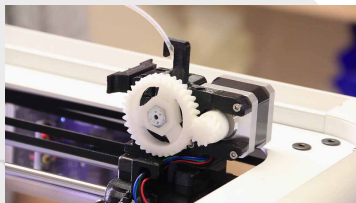

# PREPARING THE PRINT SURFACE

1

## USING WOLFBITE FOR ABS

Locate the bottle of **WOLFBITE** and the FLEX-RESISTANT glass plate that we set aside in earlier steps. Dip the foam brush into the bottle of **WOLFBITE**, then using long strokes brush on to the smooth surface of the glass plate. Cover the entire plate. One dip of the applicator brush into the **WOLFBITE** is enough to cover the entire surface. Reference the **WOLFBITE** instructions for more detailed information.

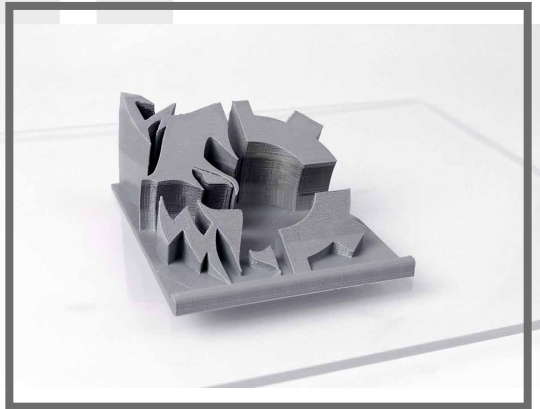

2

## INSERT GLASS PLATE INTO PRINTER

Using two hands, slide the glass plate into the metal bed brackets located on both sides of the heatbed. Slide the plate all the way in until it reaches the back of the heatbed.

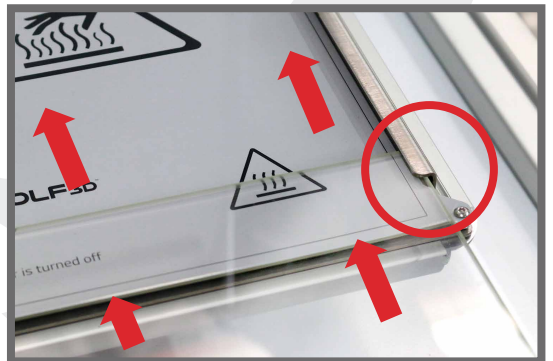
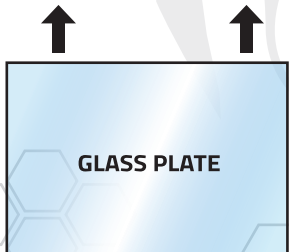

# AUTO-LEVELING PROCEDURE

---

## 1 AUTO-LEVELING PROCEDURE

### HOW IT WORKS:

AXIOM is equipped with an automatic bed leveling mechanism whereby calibration (bed leveling and z height adjustment) is performed entirely by the machine, rather than the user.

#### 1. HOME Z, X,Y

The process starts with the bed homing to Z max (bottom of the machine). The X (left) and Y (front) positions are homed thereafter. During this process, filament is retracted from the nozzle to avoid making contact with the bed. With the bed and nozzle in known positions, the bed measuring process is ready to begin.

#### 2. CLEAN NOZZLE

The first step is to raise the bed so the nozzle is cleaned by the brush. This will automatically occur at print temperature so that the plastic sufficiently melts off the nozzle tip. The nozzle will move to the back of the machine and pass across the brush multiple times. During cleaning, the filament will be further retracted to prevent it from contacting the bed during probing.

#### 3. PROBE 4 CORNERS

AXIOM will then probe 4 corners of the bed assembly. The nozzle will make contact with the bed bracket at 4 locations on the steel bed plate and complete a circuit each time. The microprocessor will remember where on the Z axis each circuit was completed (this is why it is so important that the nozzle tip is clean). With that information, AXIOM will create a virtual plane to project the part onto.

#### 4. PRINT

After probing is completed, the nozzle will move to the back left part of the machine and filament will be extruded to prime the nozzle. Thereafter the print will commence by laying a skirt around the part to be printed. During the print, the Z axis will continually adjust to provide a level surface for the part.

#### 5. CREDIT

Many thanks go to Lars Brubaker of MatterHackers for developing the auto-leveling code. This code is implemented in the open source Marlin firmware provided on your machine and supplied on your flashdrive.

# RUNNING THE FIRST PRINT

1

## SELECTING FIRST PRINT FILE

Airwolf 3D has selected an impressive ball bearing model to introduce you to AXIOM's printing capabilities.

In the **SECONDARY MENU** select **PRINT FROM SD**. Using the scroll wheel, choose the file named **BALL BEARING**. AXIOM will then preheat to the proper printing temperatures and begin the auto-leveling process. Once complete, the print will start and the model will begin printing.

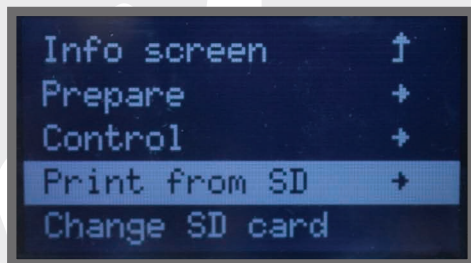

If at first you do not see the **BALL BEARING GCODE** file, scroll to **REFRESH**. Select **REFRESH** to refresh the micro SD card.

In some cases, files will not show up right away. If this happens, in the **SECONDARY MENU** select **INITIALIZE SD CARD**. You may now enter **PRINT FROM SD CARD** and can view your files.

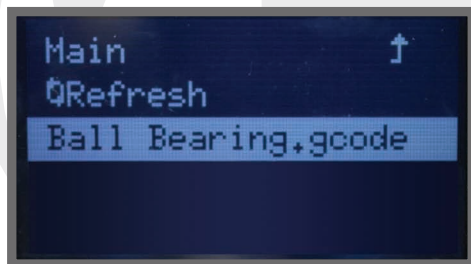

# REMOVING PARTS FROM THE BUILD PLATE

1

## LET THE PART COOL

**WOLFBITE** will automatically allow the part to release from the build plate once cool. If the part is still stuck you can run the build plate under some cold water to help release. If using water make sure to apply more **WOLFBITE** before the next print job.

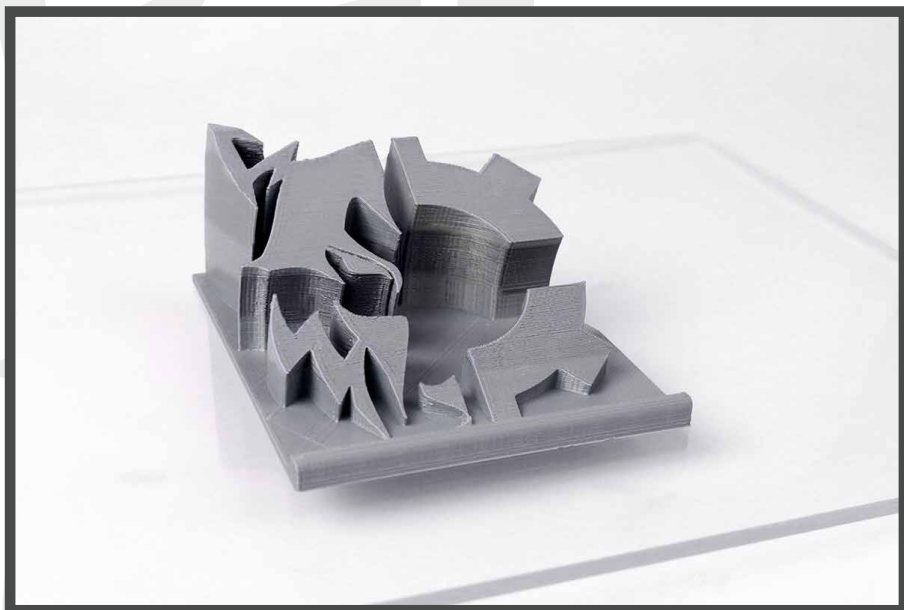

**AS PARTS COOL THEY WILL BEGIN TO “POP” OFF OF THE GLASS. DO NOT BE ALARMED, AS THIS IS JUST THE SOUND OF THE PARTS RELEASING THEMSELVES FROM THE WOLFBITE SOLUTION. COLD WATER WILL SPEED UP THE PROCESS, BUT MAKE SURE TO LET THEM COOL IN AMBIENT AIR FOR A FEW MINUTES FIRST.**

# 3D PRINTING YOUR CUSTOM PARTS: APEX

## USING APEX

APEX is a slicing program which provides an easy to use interface, advanced slicing algorithms, orientation, scale and rotation options, as well as great quality prints. APEX is installed on your USB drive.

### 1 INSTALL APEX SLICING SOFTWARE

Visit [www.airwolf3d.com/3d-printing-software](http://www.airwolf3d.com/3d-printing-software) to download the latest version of APEX.

Double-click the **.exe** file to begin the installation process.



### 2 APEX SETUP

Agree to the **license agreement**, then choose which components of APEX to install. It is recommended to select the default options, as seen in the image above.

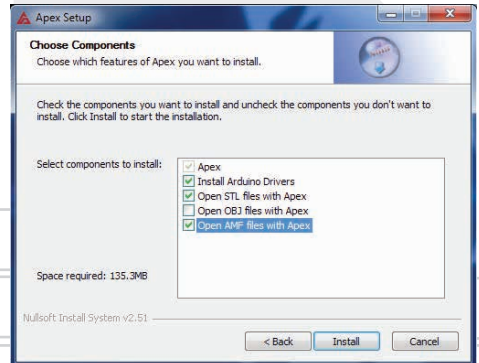
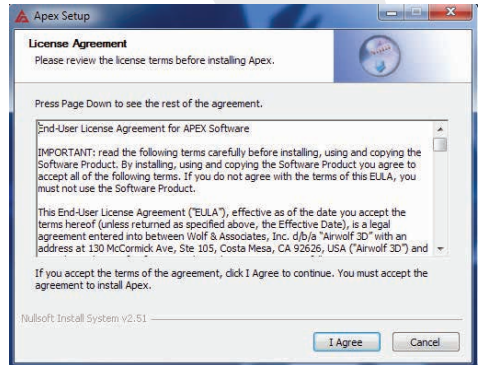

3

### CONFIGURATION WIZARD

You will now proceed with the configuration wizard. This will allow you to choose the correct Alrwolf 3D printer. On the first screen, click **NEXT**. The next screen will feature a dropdown menu with every Alrwolf 3D printer type.

Choose your printer, then click **FINISH**. **APEX** is now ready.

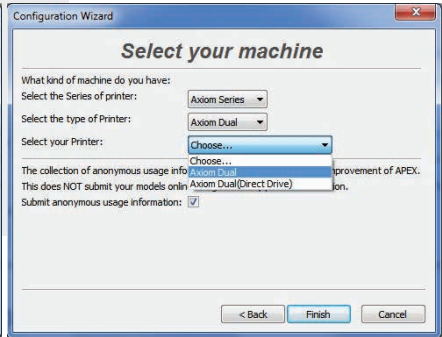
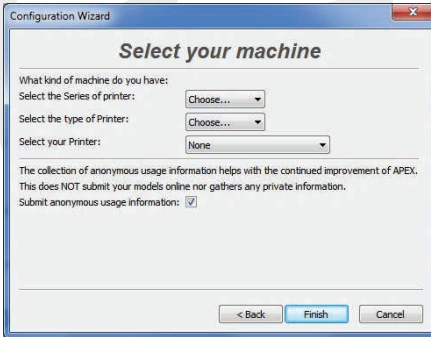

4

### USING APEX

A Welcome screen will appear when **APEX** first opens.

This screen will list the latest features that have been added to **APEX**. Click **OK**.



5

### LOADING .STL FILES

When **APEX** first opens, a sample **.stl** file will automatically preload on to the print bed. If deleted, the file will have to be manually loaded to print. To load an **.stl** file into **APEX**, go to **FILE -> LOAD MODEL FILE**, or **CTRL L**.

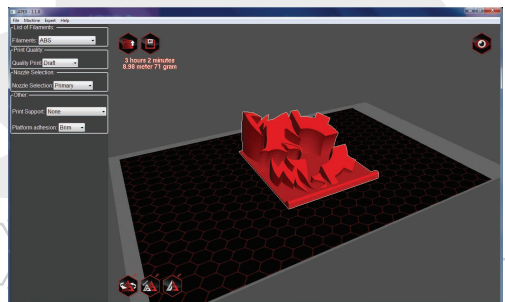

6

## USING THE QUICKPRINT MENU

In the left hand menu, you will find the **QUICKPRINT** settings. These settings have been specially developed for your Airwolf 3D printer model. By using these settings, you will get clean, consistent results.

To use the **QUICKPRINT** options, follow these steps:

4

1. Select **Filament** type (i.e. **ABS, PLA**).

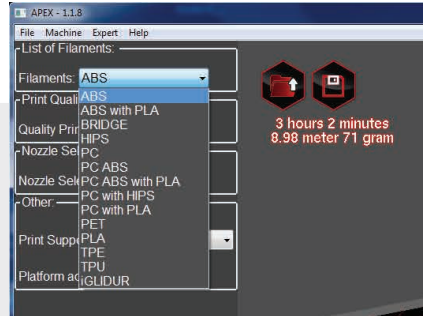

2. Select which **Nozzle** will be used (for **Dual Head** machines only).

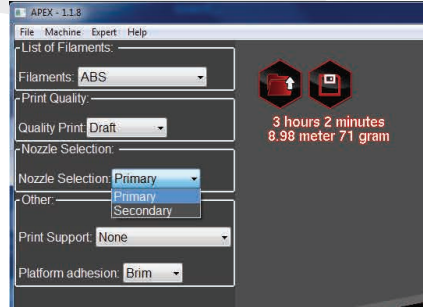

6

3. Select support material type (if your model has large overhangs, it is a good idea to choose **EVERYWHERE**).

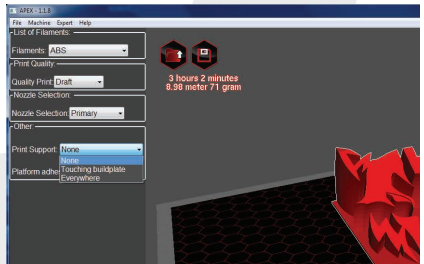

4. Select **Platform Adhesion** type (it is recommended to use a raft for most prints, a **Brim** is also recommended for **Polycarbonate** and **Nylon** prints).

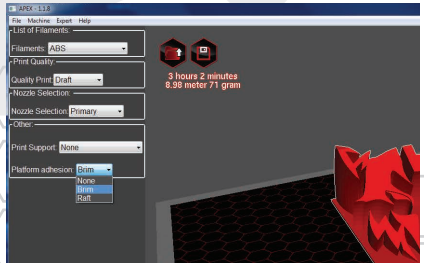

7

## USING THE TRANSFORM MENU

In **APEX**, you can manually **Rotate**, **Scale**, and **Mirror** your model. To open the transform menu, click the model to select it. The menu will now appear at the bottom left corner of the screen.



8

## ROTATE

By clicking the **ROTATE** icon, you can rotate your model in 15 degree increments by clicking and dragging one of the colored circles which have now appeared around the model.

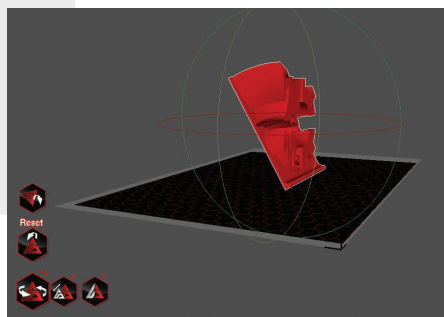

9

## SCALE

By clicking the **SCALE** icon, you can scale the model by using a percentage, or by exact dimensions. To use **SCALE**, delete the values in the text field, then type in the new value. If scaled too large, the model will turn grey and will not slice. You can scale each axis independently by clicking the lock icon.

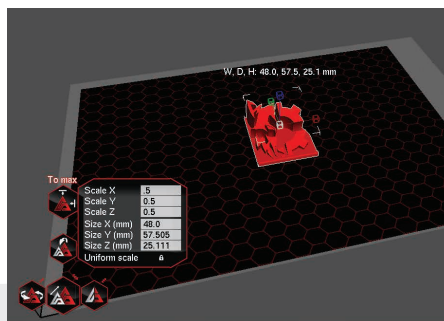

10

## MIRROR

By clicking the **MIRROR** icon, you can reflect the model in the **X**, **Y**, or **Z** axis.

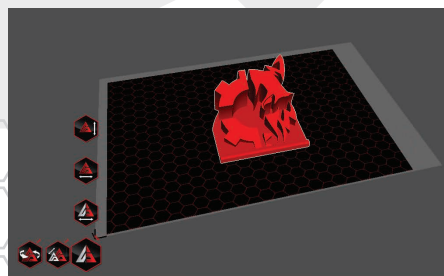

11

## VIEW MODE

Click on the **VIEW MODE** icon in the top right corner of the screen. Then click **LAYERS**. In the **LAYERS VIEW MODE**, you can use the scroll bar to drag through each layer. You will be able to view the infill, support material, and even the tool path. This is a useful way to preview the part to make sure it will print correctly.

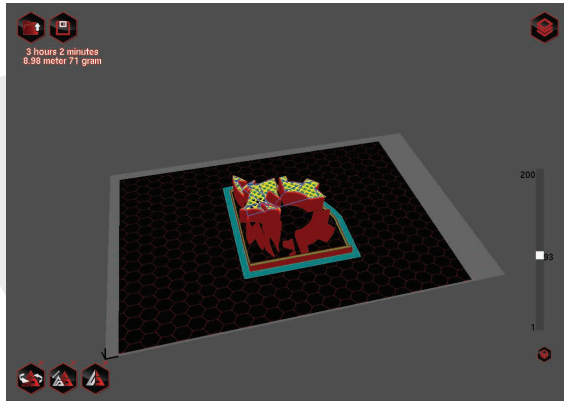

12

## SAVING GCODE

Once everything looks correct, you are ready to save and transfer the gcode file to the printer.

Go to **FILE -> SAVE GCODE**. then select the micro SD card in the file browser window, and click **SAVE**. You can remove the SD card once the **SAVED** window appears at the bottom of the APEX window.

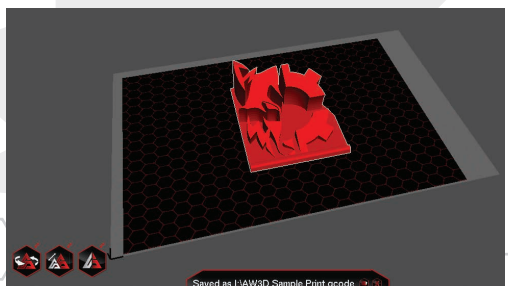
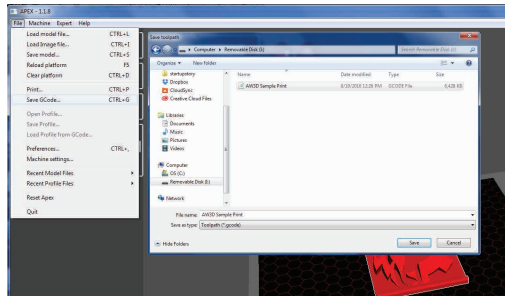

# 3D PRINTING YOUR CUSTOM PARTS: ASTROPRINT

## PRINT WIRELESSLY WITH ASTROPRINT

**APEX** is a professional software package for slicing and provides great print quality. If you would like the same print quality, but prefer using a wireless device or computer to print over the cloud, Astroprint is a good option. In order to properly use Astroprint with the AXIOM series printers, you must first use APEX to slice your model, then upload the GCODE to Astroprint. **DO NOT SLICE YOUR PARTS USING ASTROPRINT'S SLICER AND SETTINGS.**

**ASTROPRINT IS A CLOUD-BASED SOFTWARE PACKAGE THAT IS CONSTANTLY UPDATED TO IMPROVE THE USER EXPERIENCE. TO KEEP UP TO DATE ON THESE CHANGES, WE RECOMMEND YOU VISIT [WWW.ASTROPRINT.COM](http://WWW.ASTROPRINT.COM) FOR MORE INFORMATION.**

### 1 SIGN UP FOR ASTROPRINT

On a desktop or laptop computer, go to [Astroprint.com](http://Astroprint.com) and create a free account. Decide if you would like this account to be shared with multiple users or kept private. We recommend using a general company email and password so all users can access the printer. Your printer should be on and have had at least 3-5 minutes to boot up.

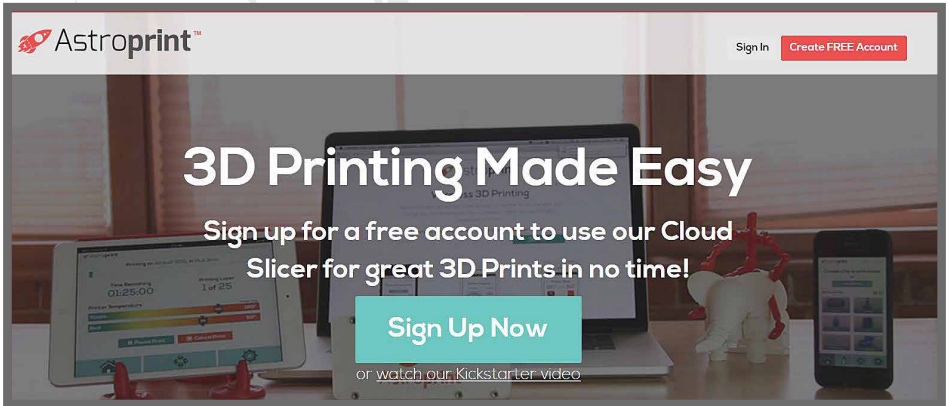

The image shows a screenshot of the Astroprint website. At the top left is the Astroprint logo with a red rocket icon. At the top right are links for "Sign In" and "Create FREE Account". The main content area features the headline "3D Printing Made Easy" in large white text. Below it is a sub-headline: "Sign up for a free account to use our Cloud Slicer for great 3D Prints in no time!". A prominent teal button says "Sign Up Now". Below the button, it says "or watch our Kickstarter video". The background of the screenshot shows a desk with a laptop, a tablet, and a smartphone, all displaying the Astroprint interface. A 3D printed red and white object is also visible on the desk.

Turn on your desired wireless device. In the **NETWORK SETTINGS**, select **Wi-Fi**. You will need to connect to the printer's hot spot for initial setup. The hot spot will be labelled AXIOM followed by your printer's serial number. This hot spot is temporary and will be shut off at the end of setup.

# ASTROPRINT

2

## WOLFBOX WiFi SETUP

The Wolfbox is the Wi-Fi board that will give you control of the printer wirelessly, and allows you to start print files. It will be attached to the astroprint.com account you created to allow access and use of your stored .STL files and GCODE.

- Open a Web Browser window on a wireless device (computer, tablet, cell phone) and type **10.10.0.1**. This will take you to the Airwolf 3D Printer setup page.
- Select **BEGIN SETUP**.
- Verify that the Airwolf Printer Name is identical to your serial number, then click **INTERNET SETUP**. You can find this number located in the inside of the printer, on the bottom panel.
- Select the Wi-Fi network you wish to connect your printer to and click **CONNECT**. If your network has a password, you will need to type this in and click **CONNECT** again.
- Success! Click on **ASTROPRINT ACCOUNT** to connect the printer to the Astroprint.com account you previously created.
- Type in your email address and password for your Astroprint account, then click **PRINTER CONNECTION**. Click **CONTINUE**.
- Verify the Baud Rate is set to 250000 and click **CONNECT**.
- Setup is now complete. Click **START PRINTING** to proceed.

### Welcome to your Airwolf3D Printer



Thank you for your purchase of an **Airwolf3D printer**. Follow these quick steps to set up your printer and get printing!

**Begin Setup**

# ASTROPRINT

3

## VERIFICATION

Ensure you are set up correctly by checking that 3 icons on the top right of your screen are green.



4

## OBTAINING THE PRINTER'S IP ADDRESS

From the menu, go to **SETTINGS**. Go to **INTERNET CONNECTION**.

Below **WIRELESS CONNECTION**, you will see the network you are connected to and the IP address of your printer. **WRITE THIS IP ADDRESS DOWN. YOU WILL NEED IT IF YOU EXPERIENCE NETWORK OR WI-FI CONNECTIVITY ISSUES.**

5

## TURN OFF THE HOTSPOT

Manually turn off the hotspot after setup is complete.

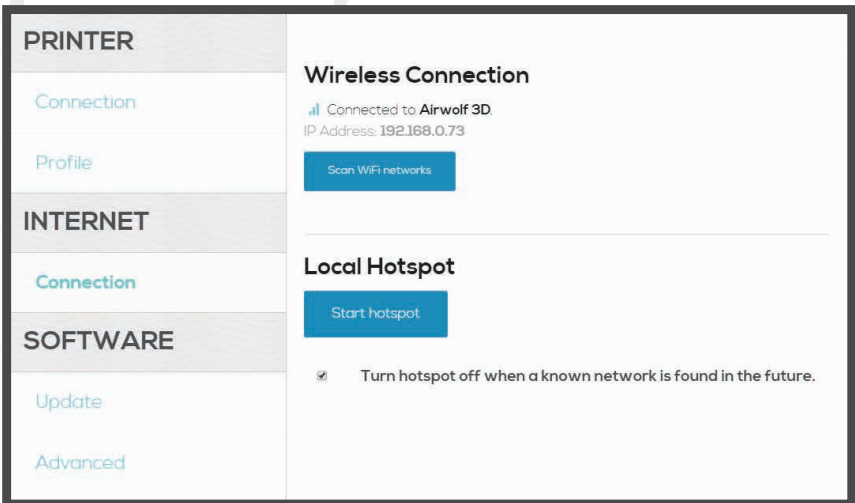

# ASTROPRINT INTERFACE

1

## MONITOR



After initial setup, this tab will display your AXIOM printer and will give you access to the Wolfbox Interface.

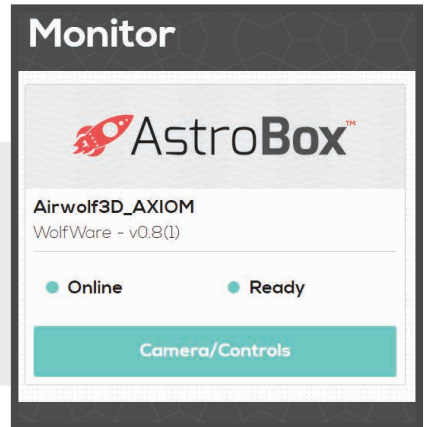

2

## CAMERA/CONTROLS

Click **CAMERA/CONTROLS** to monitor your printer. You can now view basic information such as the current temperature of the printer and what part is printing (during a print job). You also have the ability to capture photos if you attach a webcam to your Wolfbox. If you are interested in more information on connecting a webcam, please visit our tech portal.

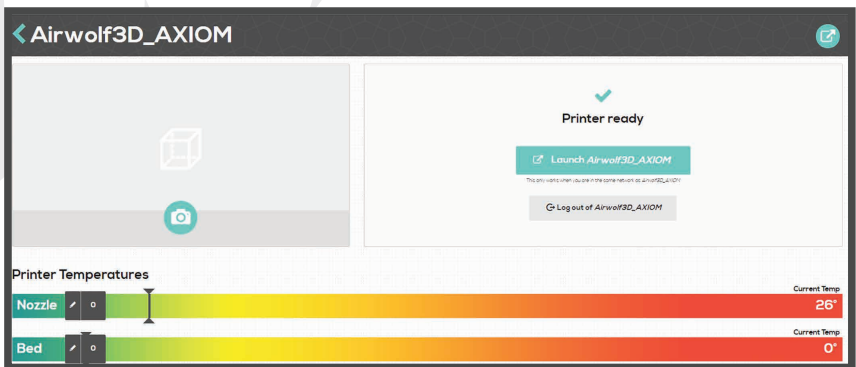

3

## CAMERA/CONTROLS

Click **LAUNCH UI**. This will open a new window in your browser with your printer's Wolfbox Interface. You must be connected to the same network that your printer was connected to during initial setup.

# WOLFBOX INTERFACE

## WIRELESS PRINTING WITH THE WOLFBOX

The Wolfbox is the printer's interface. This will be where you upload print files from your computer, download print files from your Astroprint account, and start prints.



- 1 FILE UPLOADER**   
Manually turn off the hotspot after setup is complete. Uploading stl files here will still be sliced using Astroprint.com.

- 2 FILE MANAGER** 



### UPLOAD FILE (gcode)

- Allows you to upload an gcode file from your computer to your AstroPrint account.
- Allows you to upload a GCODE file directly to your Wolfbox. This will not be stored on your AstroPrint account, only on the Wolfbox.

# WOLFBOX INTERFACE

---

## UPLOAD FILE (gcode)

- Allows you to upload an gcode file from your computer to your AstroPrint account.
- Allows you to upload a GCODE file directly to your Wolfbox. This will not be stored on your AstroPrint account, only on the Wolfbox.

## SYNC

- Synchronizes the Wolfbox with your AstroPrint account so you can view and download print files that have recently been sliced on your AstroPrint account.

## LOCAL

- Shows you only files that have been sliced or run through this printer's interface. You will not be able to see any files that were sliced using your AstroPrint account.

## CLOUD

- Shows all print files on both the Wolfbox and your AstroPrint account. Print files that have not been downloaded to the Wolfbox yet will be faded out. You can download them to your Wolfbox, or start the print by clicking on them and selecting either the cloud icon (to download the print file to the Wolfbox without starting the print) or the printer icon (to download the print file to the Wolfbox and immediately start the print).

# WOLFBOX INTERFACE

3

## CONTROL



Click **ADD PRINTER** if the printer model is not already available in the list.

### XY PLANE (HORIZONTAL)

- X and Y movement of the hotend.
- The house icon will move the hotend to its home position (front left).

### Z PLANE (VERTICAL)

- Z movement of the heat bed.
- The house icon will move the heat bed to its home position
- The add and subtract options are for distances away from the hot end. So adding distance means the heat bed will go down and subtracting distance will cause the heat bed to go up.

### MOVEMENT INCREMENT CONTROL

- Displayed in millimeters, the amount of movement you would like in the X, Y, or Z axis.

# WOLFBOX INTERFACE

---

## EXTRUDE FILAMENT

### SELECT NOZZLE

- Nozzle one is on the left side of your hotend and nozzle two is on the right.

### FILAMENT AMOUNT

- Increment control specific to filament extrusion/retraction.

### EXTRUDE

- Clicking this will push the filament through the hotend by the amount selected in **FILAMENT AMOUNT**.

*Hotend must be heated to preheat temp before attempting to extrude filament.*

### RETRACT

- Clicking this will pull filament back out of the hotend by the amount selected in **FILAMENT AMOUNT**.

*Hotend must be heated up to temp before attempting to retract filament.*

### CURRENT TEMP

- When sitting idle, both displays will read room temperature in Celsius.
- Temperature is controlled and set by the scrollbars at the bottom. This allows the user to control the hotend temperature, as well as the heatbed temperature.
  - Set the Nozzle Temperature to 240C by dragging the scroll bar up. This will set the target temperature to 240C. The Current Temp will start to increase.
- The side fan on the hotend can also be turned off and on with the ON/OFF button.
  - The fan on the back of the hotend is controlled by the printer, not the user.

# WOLFBOX INTERFACE

4

## SUPPLIES



This tab will take you to Airwolf 3D's store for purchasing Wolfbite, glass, filament, and more.

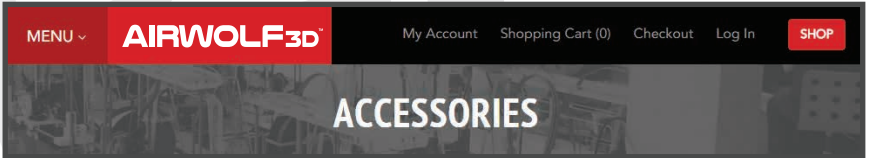

5

## SETTINGS

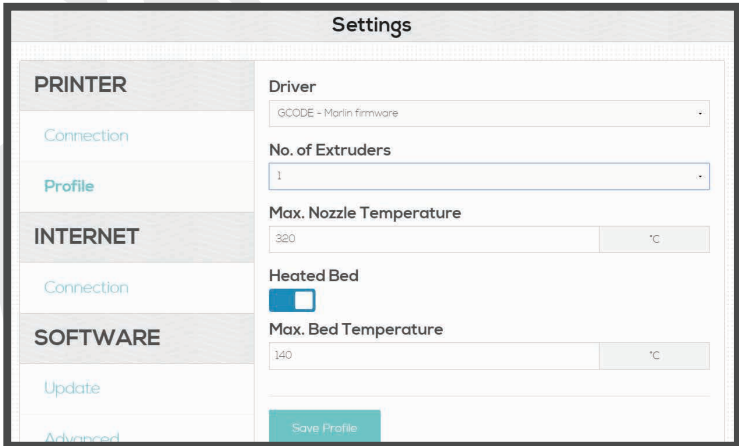

# WOLFBOX INTERFACE

---

## PRINTER

### CONNECTION

- Here you can change the Baud Rate to 250000 if this step was missed previously. If you are ever having connection difficulties, **TEST CONNECTION** can also be found here.

### PROFILE

- Maximum temperatures for your printer. Do not change these settings to temperatures your printer is incapable of.

### FINAL WOLFBOX SETUP

- Change the maximum nozzle temperature for AXIOM to 320, and make sure the bed is set to 140.

## INTERNET

### WIRELESS CONNECTION

- View what network you are connected to.
- IP Address location.

### LOCAL HOTSPOT

- After setup, the hot spot is shut off for security purposes. If you would like the hot spot to remain on, uncheck the box for **TURN HOTSPOT OFF WHEN A KNOWN NETWORK IS FOUND IN THE FUTURE**.
- You can still connect directly to the Wolfbox by navigating through [astroprint.com](http://astroprint.com) to the monitor tab, typing the IP address in your browser, or going to your printers network folder and clicking on your printer under **OTHER DEVICES**.

# WOLFBOX INTERFACE

- You can still connect directly to the Wolfbox by navigating through [astroprint.com](http://astroprint.com) to the monitor tab, typing the IP address in your browser, or going to your printers network folder and clicking on your printer under **OTHER DEVICES**.

## SOFTWARE

### UPDATE

- Check for recent updates.

### ADVANCED

- Restore Factory Settings.
  - Disconnects the Wolfbox from the Astroprint account and Wi-Fi network, and turns on the hotspot.

### LOGS

- Send logs to Astroprint. This option is used for troubleshooting errors with astroprint. Checking the **TURN ON SERIAL LOGS** should only be used if there are communication errors occurring.

6

## SUPPORT



This tab will take you to Airwolf 3D's Tech Assistance Portal (<https://airwolf3d.freshdesk.com>)

- Solutions are available for unboxing the printer, maintenance, troubleshooting, and more. If you are having any kind of issue, check here.
- If you do not find a solution, submit a ticket for assistance from our technicians.



**AIRWOLF<sub>3D</sub> Technical Assistance** Welcome  
Login Sign up

Home Solutions

How can we help you today?

Enter your search term here...

[+ New support ticket](#)  
[📄 Check ticket status](#)

# USB PRINTING WITH REPETIER HOST

## INSTALLING RAMBo DRIVERS

In order to print directly from your PC (MACS do not require RAMBo drivers) to AXIOM, you must first install the drivers for the main controller board. Using the Repetier Host software, you will be able to manually control and start/stop/pause prints, just as if you were operating the printer from the LCD control screen.

### 1 PLUGGING IN THE USB CABLE AND USB DRIVE

Plug the USB cable located in the accessories box into your computer and then into the printer. Locate the USB drive used earlier and insert it into a free USB port on your computer.

### 2 INSTALL THE DRIVERS

On your PC, open the **CONTROL PANEL**. Locate and click on **DEVICES AND PRINTERS**. Scroll down to **UNSPECIFIED**. If the printer has been plugged into the computer, you will see a device named **RAMBo**. Right click the large icon and select **PROPERTIES**. A new window will appear. Under the second tab labeled **HARDWARE**, select **PROPERTIES**. A second RAMBo Properties window will now open. Under the **GENERAL TAB**, select **UPDATE DRIVER**.

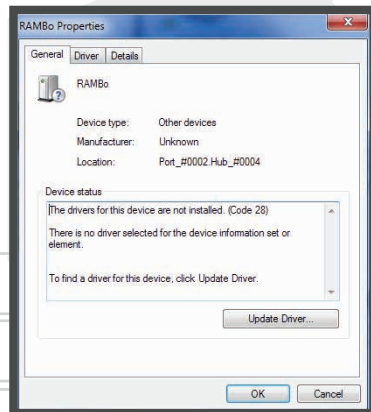
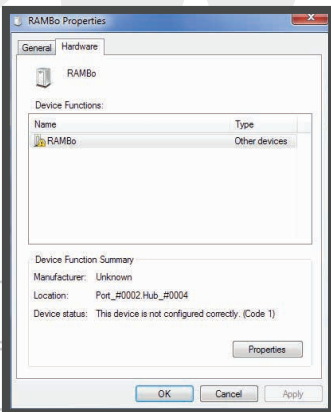
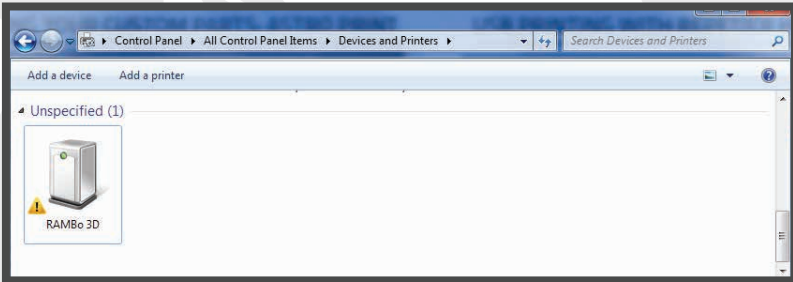

# USB PRINTING WITH REPETIER HOST

## PRINTING FROM REPETIER HOST

If you prefer to 3D print via USB directly from a computer, Repetier Host will be used to control and communicate with the printer. You will be able to perform all manual printer functions, as well as start, pause and stop print jobs. Repetier Host includes a fantastic GCODE viewer as well, so if you forget to check your GCODE in APEX, you can check it in Repetier Host before starting a print job.

### 1 DOWNLOAD AND OPEN REPETIER HOST

Repetier Host can be downloaded from: [www.repetier.com](http://www.repetier.com)

Run the install file. Once the installation is complete, click **FINISH**. Open the software. Click **PRINTER SETTINGS** in the upper right menu. A new window will open. You will now be in the **CONNECTION** tab of the new window.

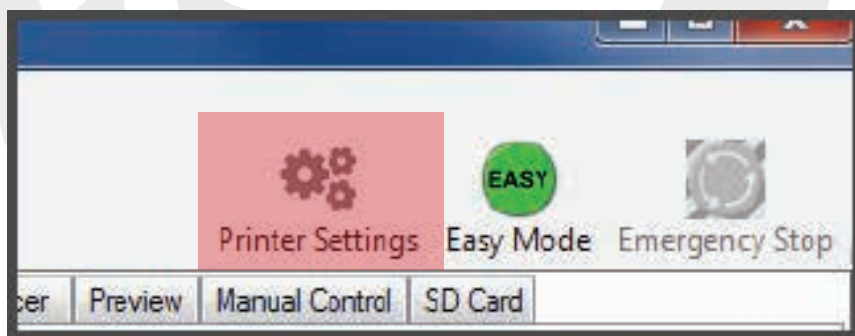
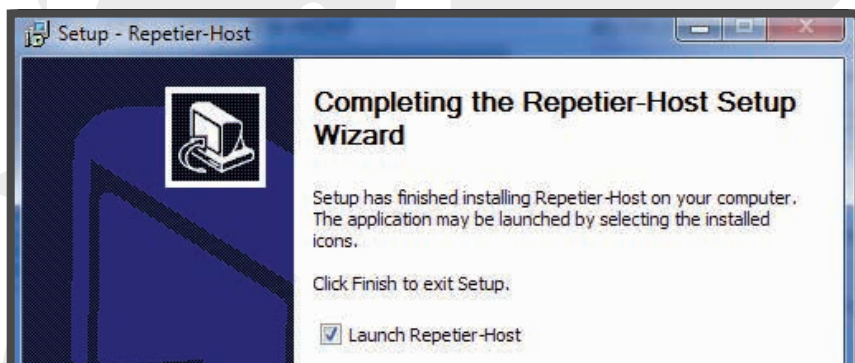

### 2 CONNECTION TAB SETTINGS

Repetier Host can be downloaded from: [www.repetier.com](http://www.repetier.com). Name the printer. Replace **DEFAULT** with a new printer name (i.e. AXIOM). While still in the **CONNECTION** tab, change the Baud Rate to 250,000. Select the Port that was assigned to the RAMBo board in the **CONTROL PANEL** during **RAMBo DRIVER INSTALLATION**.

# USB PRINTING WITH REPETIER HOST

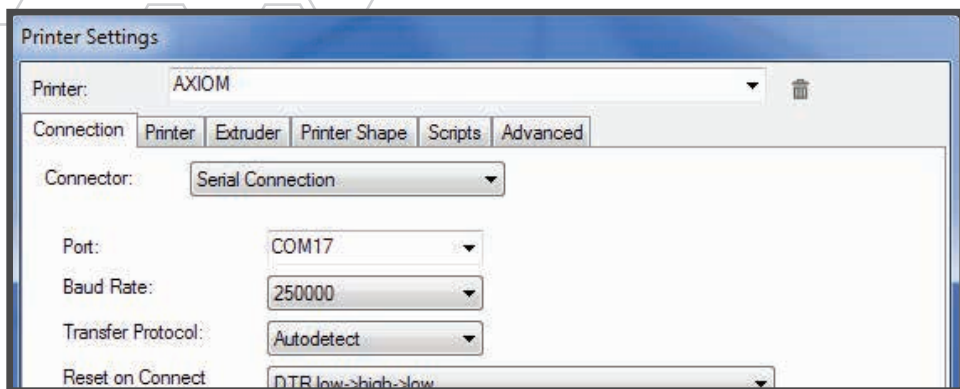

Printer Settings

Printer: AXIOM

Connection Printer Extruder Printer Shape Scripts Advanced

Connector: Serial Connection

Port: COM17

Baud Rate: 250000

Transfer Protocol: Autodetect

Reset on Connect: DTR low->high->low

## 3 PRINTER TAB

Click on the **PRINTER** tab, then change the **DEFAULT EXTRUDER TEMPERATURE** to 250C, and the **DEFAULT BED TEMPERATURE** to 120C. Manual Extrusion Speed: 1 & 5 mm/s

- Use 1 for TPU and other soft materials
- Use 5 for ABS and other hard materials

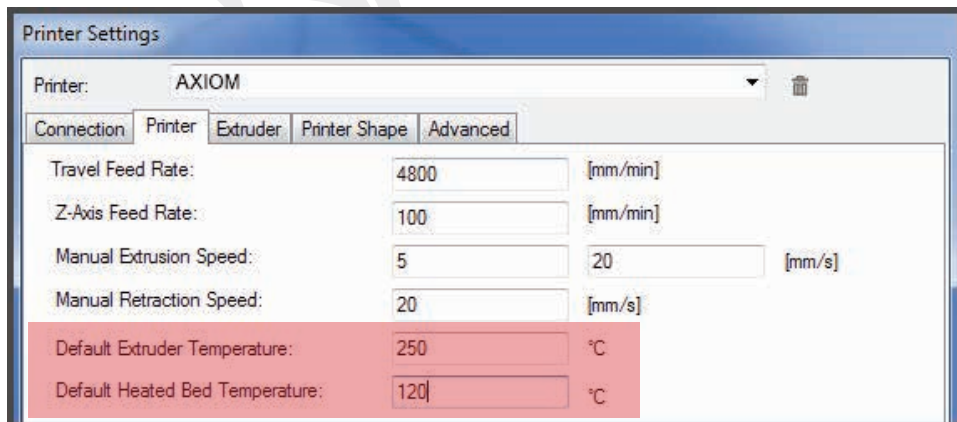

Printer Settings

Printer: AXIOM

Connection Printer Extruder Printer Shape Advanced

Travel Feed Rate: 4800 [mm/min]

Z-Axis Feed Rate: 100 [mm/min]

Manual Extrusion Speed: 5 20 [mm/s]

Manual Retraction Speed: 20 [mm/s]

Default Extruder Temperature: 250 °C

Default Heated Bed Temperature: 120 °C

## 4 EXTRUDER TAB

Click on the **EXTRUDER TAB**, then select 1 under **NUMBER OF EXTRUDERS**. Enter 320 for **MAX. EXTRUDER TEMPERATURE**, 140 for **MAX. BED TEMPERATURE**, and leave 12 for **MAX VOLUME PER SECOND**. Change the diameter of **EXTRUDER 1** to .5 mm. If using an optional .35 nozzle, enter .35.

# USB PRINTING WITH REPETIER HOST

Printer Settings

Printer: AXIOM

Connection Printer **Extruder** Printer Shape Advanced

Number of Extruder: 1

Max. Extruder Temperature: 320

Max. Bed Temperature: 140

Max. Volume per second: 12 [mm<sup>3</sup>/s]

Printer has a Mixing Extruder (one nozzle for all colors)

Extruder 1

Name:

Diameter: 0.5 [mm] Temperature Offset: 0 [°C]

Color:

Offset X: 0 Offset Y: 0 [mm]

## 5 PRINTER SHAPE TAB

Click on the **PRINTER SHAPE TAB**. Set the **X MAX** to 280, and the **Y MAX** to 200. This sets the maximum travel the head is able to reach in these directions. For the print area, set the **WIDTH** to 317.5, the **DEPTH** to 203, and the **HEIGHT** to 254. Click **APPLY** and **OK** to save the settings as default.

Printer Settings

Printer: AXIOM

Connection Printer Extruder **Printer Shape** Advanced

Printer Type: Classic Printer

Home X: Min Home Y: Min Home Z: Min

X Min: 0 X Max: 317.5 Bed Left: 0

Y Min: 0 Y Max: 200 Bed Front: 0

Print Area Width: 317.5 mm

Print Area Depth: 203 mm

Print Area Height: 254 mm

The min and max values define the possible range of extruder coordinates. These coordinates can be negative and outside the print bed. Bed left/front define the coordinates where the printbed itself starts. By changing the min/max values you can even move the origin in the center of the print bed, if supported by firmware.

# USB PRINTING WITH REPETIER HOST

## 6 LOAD GCODE

Using APEX, export GCODE on to your hard drive. In previous steps, we saved GCODE on to the micro SD card and then inserted it into the LCD for printing. We will now be printing directly from the computer, so no SD card is needed. We will first **CONNECT** to the printer, then we will load GCODE.

- Press **CONNECT** to connect to the printer.
- Press **LOAD > (GCODE FILE.GCODE)** to import the GCODE file.

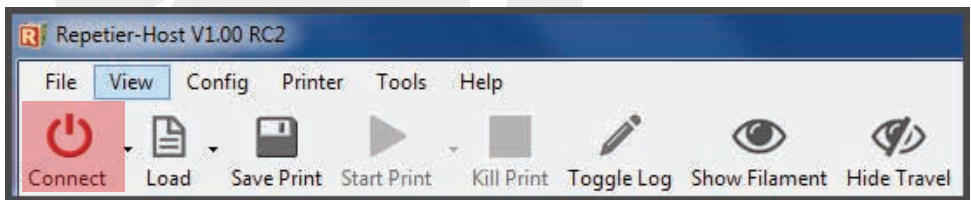

## 7 ANALYZING THE GCODE

Under the **PREVIEW TAB** you will be able to see a 3D view of the GCODE file. As experience is gained, this step will greatly improve the quality of prints and also give the user a better understanding of the slicing process. It is a good idea that when starting out, the user looks at the GCODE first to get a better understanding of how the settings were applied. In this tab, the user can scroll through the GCODE file layer by layer to do a deeper analysis of the sliced part. It will also give you the estimated printing time.

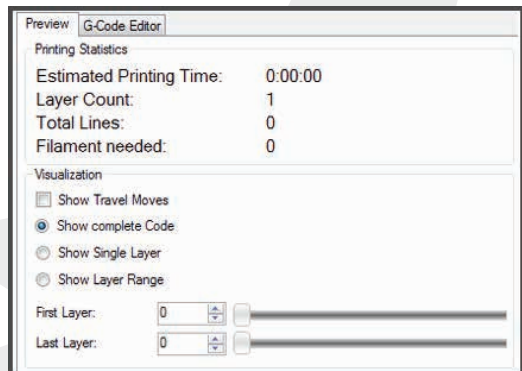
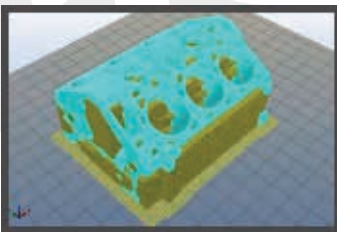

## 8 LOAD FILAMENT/PRIME

Use the **LOAD FILAMENT** command on the LCD to load the correct filament into the hotend. You can now prime the hotend using the **EXTRUDE** button in Repetier Host.



## USB PRINTING WITH REPETIER HOST

### 9 PREHEAT THE HOTEND AND BED

Under the **MANUAL CONTROL TAB**, click the **EXTRUDER ICON** to preheat the hotend. Do the same with the **BED ICON** to preheat the heatbed.

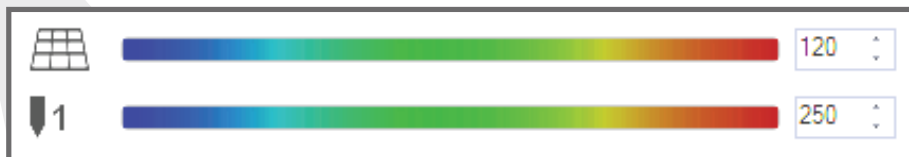

### 10 START THE PRINT

Once pre-heated, AXIOM is ready to start the print. Press the **START PRINT** button to begin printing.



## CHANGING FILAMENT

### CHANGING FILAMENT IS EASY

Changing filament types on the AXIOM is easy. No more fiddling with pins, latches and levers. AXIOM allows for easy feeding and removal of filament, and makes priming easy. AXIOM can be running polycarbonate at 300C for hours, and can easily be purged with flexible filament in a matter of minutes. In the past, this was unheard of.

### 1 PREHEAT AND REMOVE FILAMENT

Using the LCD, preheat the hotend to the correct temperature for the loaded filament. This can be done using **PREPARE-> PREHEAT ABS/PLA/PC**, or if using something other than these materials, you can go to **CONTROL-> TEMPERATURE-> NOZZLE**. You can then use the wheel on the LCD to set the correct temperature for the material currently in the printer. See the **FILAMENT GUIDE** on page 35 for correct temperatures.

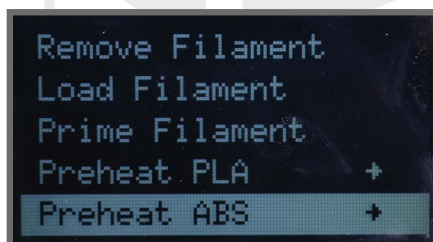

# CHANGING FILAMENT

## 2 REMOVE PREVIOUS FILAMENT

Once the hotend has been preheated to the melting temperature of the loaded filament, use the **REMOVE FILAMENT** command on the LCD to remove the filament. Once activated, the filament will begin to unload from the extruder. As it is retracting back through the extruder, make sure to wind the filament on to the roll currently on the machine. Once complete, remove the roll and insert the new desired filament.

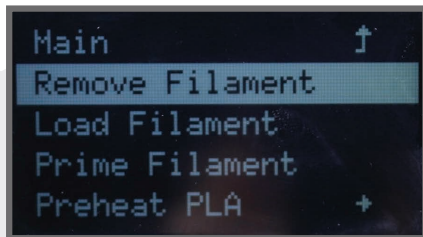

## 3 LOADING AND PRIMING NEW FILAMENT

If the new filament is of lower temperature than the previously loaded filament, we will not adjust the hotend temperature before priming. If the new filament has a higher melting temperature, we will adjust the printer to this temperature before priming. In the **CONTROL** menu on the LCD, raise the temperature accordingly.

If the new material has a lower melting point, we will prime the hotend using the temperature of the previous filament. This is especially important when changing from a high-temperature material such as polycarbonate, to a low-temperature material such as TPU or PLA.

Once you have the correct hotend temperature, go to **PREPARE-> LOAD FILAMENT (See LOADING FILAMENT on page 7 for more info)**. Once the material is loaded into the hotend, we will want to purge out all of the old unwanted material with the new material. To do this, navigate to **PRIME FILAMENT** in the **PREPARE** menu of the LCD. This command will extrude 50mm of material. Repeat this step until you see a consistent flow of the new material. Once you have achieved this, change the hotend temperature to the current material's desired melting temperature. See the **FILAMENT GUIDE** on page 35 for more information regarding temperatures.

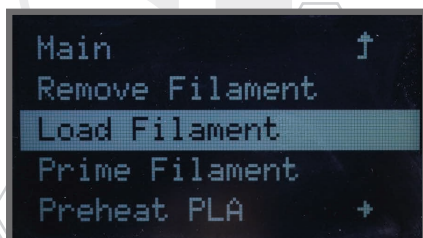

# TIPS AND TRICKS

## TIPS AND TRICKS FOR 3D PRINTING

3D Printing can be easy and fun, but it can also be challenging. Not all models are the same, and not all materials provide the same results. Orientation, bed adhesion techniques, settings - these are all things that will greatly affect the outcome of a print. Take a look at our guide below to help you get through some of the more challenging aspects of desktop 3D printing.

### START UP

- Make sure the entire interior of the AXIOM is clean and clear of any filament debris, accessories, etc.
- Use the Auto Home feature to put the bed in position for surface preparation (Wolfbite, etc.) - bed will lower to maximum travel first (Z) and then home X and Y.
- Preheat the printer before attempting to load or remove any filament.

### LOADING/REMOVING/PRIMING FILAMENT

**GCODE** (when using Repetier Host or similar host software)

M601 - Retracts filament

M602 - Loads filament (5 second delay until extruder motor runs)

M603 - Primes filament

### LOADING

When loading filament, if it starts to bind up as it nears the tip, gently move tubing out from hook on hotend so the path is smoother.

After filament has exited the tip, move the tube back under the hook.

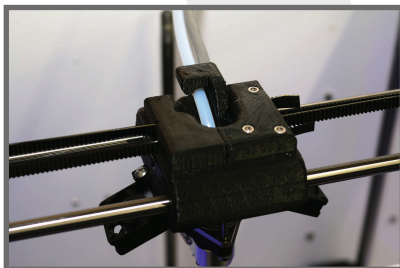
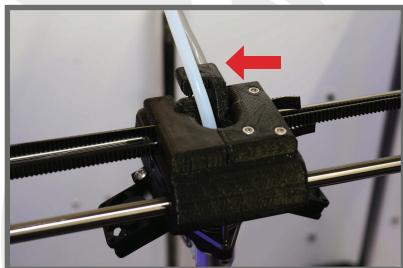

### REMOVING

When removing PLA and other PLA-based materials the filament may get stuck in the tubing near the hotend because of the expansion of the material. If so, press down on the push-to-connect fitting with a screwdriver and remove tubing. That may be enough release to let the filament retract. If not, prime the filament and then cut the oversized filament off the end. The filament should then pass back through the tube easily. TPU and TPE will compress and it will be necessary to activate the **REMOVE FILAMENT** function twice to account for compression.

### PRIME

Prime can be used to make sure old filament is sufficiently purged out of the hotend. This is particularly useful when going from high-temp materials like PC to lower temp materials like PLA and TPU. If PC is not sufficiently primed, it will cause the hotend to jam when printing lower-temp materials like PLA and TPU. TPU and TPE will need to be primed repeatedly as well because of their compression in the PTFE guide tube.

# TIPS AND TRICKS

---

## **AUTO LEVELING**

If the first layer height is not correct, cycle power and try again. The nozzle tip must make contact with the brush to clean the tip. The tip must also be hot to make sure it makes sufficient contact with the bed to complete a circuit and develop the virtual plane for the microprocessor to perform auto leveling.

## **GCODE GENERATION**

It is imperative that the user **ONLY** uses Airwolf slicing profiles. These profiles have the correct start and end gcode that properly activates auto leveling. Without this information, the printer will not work correctly.

## **PRINT SIZE**

While possible to print to the outer limits of the printer, the most consistent results will come from modest build sizes. Keeping prints within 11"x7.5"x9" will tend to produce easily repeatable parts in a wide variety of materials.

## **ENVIRONMENTAL FACTORS**

For PC, ABS, HIPS, and other higher-temp materials, it is best to keep the print volume enclosed. For PET and PLA-based filaments, removing the top lid will promote cool airflow into the print area to give best results. For these materials, all three fans should be operational during the majority of the print.

## **SMALL PRINTS**

For small prints, know what material bed temps should be lowered to reduce the chance of lower-layer warpage. Also, a raft is frequently a good idea as it further isolates heat from the build plate and promotes a consistent first layer.

## **SPEEDS**

For draft-style prints, 80mm/s for printing and 175mm/s for travel moves should work fine with most materials except for softer materials like TPE and TPU, in which case 40-60mm/s will work better for printing.

## **LAYER HEIGHTS**

The AXIOM will produce high quality prints at .25mm layer heights. This in fact is the layer height used for Airwolf's 3D Hubs print service. Resolution will increase with finer layer heights, but bridging may be more difficult, and time will significantly increase. Internally we tend to print at .2-.3mm layer height 95% of the time.

## **WOLFBITE**

To promote the best adhesion for the parts to the Flex-Resistant Glass, apply Wolfbite, Wolfbite NANO, Wolfbite MEGA, or Wolfbite NITRO as necessary. No more than 2 layers is needed. All solutions will dissolve in water. To clean, soak the build plate in water and use a sharp razor to carefully remove the leftover solution and plastic.

# MAINTENANCE

## MAINTENANCE IS IMPORTANT

To ensure a long life for your new AXIOM 3D printer, it is highly recommended you perform regular maintenance. Build plate maintenance, hotend care, and lubrication are all very important when it comes to an excellent performing machine. If you continue to maintain your printer, you will greatly increase its lifespan. See the guide below for maintenance procedures and descriptions.

### SERVICE INTERVALS

#### Flex-Resistant Glass

Rated for 75-150 hours - after extensive cycling will need to be replaced because surface will become brittle.

#### HOTEND

Every 50-100 hours supplied .5mm drill bit should be used to clean tip outlet - too much compression on build plate or different material use can close tip outlet. The hotend is rated for 750-1500 hours, dependent on material used - lower temp will generally give longer service life.

#### LUBRICATION

All smooth rods should be lubricated every 100-150 hours with lithium grease.

### NOZZLE REMOVAL/REPLACEMENT

Heat the nozzle to the printing temp of the current material being used. Remove the material from the hotend. Be careful, the nozzle will be extremely hot (USE GLOVES). Use pliers to hold the heating element and remove the 2 button head screws with a straight end allen wrench/hex drive. Remove the nozzle and set it aside **IT IS STILL HOT!** Use a razor blade to scrape the debris off of the bottom of the heating element. Now let the nozzle cool. Depending on how much filament is in the nozzle, you may have to soak it in acetone from 2-12 hours. **ONLY USE INCLUDED NOZZLE TOOL TO CLEAR YOUR TIP!** Replace the nozzle once it is cool, remember to use the spring washers and tighten the 2 screws down snug. **DO NOT OVER TIGHTEN!** Remember to use the pliers to hold the heating element as well.

# TROUBLESHOOTING

---

## **PART WON'T STICK TO BUILD PLATE**

Ensure you are using the proper bed adhesion method. Wolfbite bed adhesion solutions should be used for ABS, PLA, PC/ABS, PC, PETG, and TPU. See the **FILAMENT GUIDE** on page 35 for more information.

Make sure your part is oriented correctly on the build plate. You can use Repetier Host or APEX to preview the GCODE before printing to make sure the first layer is properly being laid down on the build plate.

## **WOLFBITE WILL NOT RELEASE PART**

Run the build plate (with part attached) under cold water after it has cooled in ambient air temperature. If the part does not release right away, wait a few minutes. The water will eventually soak between the part and the glass surface.

## **PARTS WARPING**

It is important that while printing with materials like ABS, PC, and PC/ABS that the front door and top panel remain closed during the entire print. If open, ambient air can cause the print to shrink which in turn can cause unwanted warping and cracking.

## **MATERIAL IS NOT EXTRUDING**

Heat the hotend 10–20 degrees higher than the desired material temperature and try using the PRIME function to extrude some material at a higher temperature. If you hear a **CLICKING** sound, you can manually remove the material by pulling it out of the hotend and extruder assembly. Locate the **MOUSE BITE** (area where extruder hobbled bolt ate through the filament causing a “mouse bite”) and cut the filament just below the **MOUSE BITE**. Discard the bad filament and cut the new tip at an angle. You can now re-feed the material into the hotend and begin printing.

If material still will not feed, you may have a dirty or damaged nozzle. See the **TIPS AND TRICKS** and **MAINTENANCE** sections for more info on changing/cleaning nozzles.

## **AIRWOLF 3D TECHNICAL ASSISTANCE**

If you are still having problems, Airwolf 3D is here to help. Please visit our Tech Portal at (<https://airwolf3d.freshdesk.com>)

- Solutions are available for un-boxing the printer, maintenance, troubleshooting, and more. If you are having any kind of issue, check here.
- If you do not find a solution, submit a ticket for assistance from one of the Airwolf 3D technicians.

# WARRANTY INFORMATION

## LIMITED WARRANTY

AIRWOLF 3D warrants its printers and its parts against defects in materials or workmanship for **TWELVE (12) MONTHS** from the original delivery date. This limited warranty extends only to the original purchaser. During this period, AIRWOLF 3D will repair or replace defective parts with new or reconditioned parts at AIRWOLF 3D's option, without charge to the original purchaser. This repair is limited to parts and labor at AIRWOLF 3D's facilities only. All shipping fees both to and from AIRWOLF 3D during the 12 month period must be paid by the original purchaser.

Please note that any warranty services or questions must be accompanied by the order number and original invoice from the transaction through which the warranted product was purchased. The order number and original invoice serves as your warranty number and must be retained. AIRWOLF 3D will not provide warranty service without the order number and original invoice.

All original parts (parts installed by AIRWOLF 3D at the original system build) replaced by AIRWOLF 3D or its authorized service center, are warranted. Any aftermarket additions or modifications are not warranted. The original purchaser is responsible for the payment for any service or repair outside the scope of this limited warranty.

AIRWOLF 3D makes no other warranty, either express or implied, including, but not limited to, implied warranties of merchantability, fitness for a particular purpose, or conformity to any representation or description, with respect to its printers other than as set forth below. AIRWOLF 3D makes no warranty or representation, either express or implied, with respect to any other manufacturer's product or documentation, its quality, performance, merchantability, fitness for a particular purpose, or conformity to any representation or description.

Except as provided herein, AIRWOLF 3D is not liable for any loss, cost, expense, inconvenience or damage that may result from use or inability to use the product. Under no circumstances shall AIRWOLF 3D be liable for any loss, cost, expense, inconvenience or damage exceeding the purchase price of the computer, less any shipping fees.

The warranty and remedies set forth herein are exclusive and in lieu of all others, oral or written, expressed or implied. No reseller, agent or employee is authorized to make any modification, extension or addition to this warranty.

## WARRANTY CONDITIONS

AIRWOLF 3D's Twelve (12) Month Limited Warranty is subject to the following conditions:

1. This warranty extends only to printers distributed and/or sold by AIRWOLF 3D. It is effective only if the printers are purchased and operated in the USA.
2. This warranty covers only normal use of the printer. AIRWOLF 3D shall not be liable under this warranty if any damage or defect results from (i) misuse, abuse, neglect, improper shipping or installation; (ii) disasters such as fire, flood, lightning or improper electric current; (iii) service or alteration by anyone other than an authorized AIRWOLF 3D representative; or (iv) damages incurred through irresponsible or other non-recommended practices.
3. You must retain your order number and original invoice to receive warranty service.
4. No warranty extension will be granted for any replacement part(s) furnished to the original purchaser in fulfillment of this warranty.
5. AIRWOLF 3D makes no warranty (either expressed or implied) regarding thirdparty (non-AIRWOLF 3D) installed parts or products.

## WARRANTY EXCLUSIONS

AIRWOLF 3D accepts no liability for problems caused by after-market modifications or additions to its printer. AIRWOLF 3D is not responsible for any loss of work ("down time") caused by a product requiring service. This warranty is null and void if the defect or malfunction was due to damage resulting from operation not within manufacturer specifications. It is also null and void if there are indications of misuse and/or abuse. AIRWOLF 3D has the option of voiding the warranty if anyone other than an AIRWOLF 3D technician attempts to service the product. AIRWOLF 3D will not warrant any problems arising from an act of God (lighting, flooding, tornado, etc.), electrical spikes or surges, or problems arising out of hardware, software, or additional devices added to complement any product bought at AIRWOLF 3D. AIRWOLF 3D will not be held responsible for **typographical errors on sales receipts, repair tickets, or on our website. AIRWOLF 3D makes every effort to make sure all information on our website is correct.**

# TERMS OF USE

---

## TERMS OF USE

**FAIR USE NOTICE:** This directory may contain copyrighted material. Such material is made available for informational and educational purposes, to advance understanding of 3D printers, 3D printing, and computer-aided modeling for 3D printing. This constitutes a “fair use” of any such copyrighted material as provided for in Title 17 U.S.C. section 107 of the US Copyright Law. In accordance with Title 17 U.S.C. Section 107, the material on this site is distributed without profit to those who have expressed a prior interest in receiving the included information for research and educational purposes. If you wish to use copyrighted material from this directory for purposes of your own that go beyond “fair use”, you must obtain permission from the copyright owner.

Most of the models contained in this directory are subject to licenses. The “Thing” No. of the model corresponds to the thing as referenced on [www.thingiverse.com](http://www.thingiverse.com). Thingiverse.com identifies the particular license associated with the specific model. The licenses can be found at <http://creativecommons.org/>.

THESE MODELS ARE PROVIDED “AS-IS” AND “AS AVAILABLE” AND AIRWOLF 3D (AND OUR SUPPLIERS) EXPRESSLY DISCLAIM ANY WARRANTIES AND CONDITIONS OF ANY KIND, WHETHER EXPRESS OR IMPLIED, INCLUDING THE WARRANTIES OR CONDITIONS OF MERCHANTABILITY, FITNESS FOR A PARTICULAR PURPOSE, TITLE, QUIET ENJOYMENT, ACCURACY, OR NON-INFRINGEMENT. WE (AND OUR SUPPLIERS) MAKE NO WARRANTY THAT THE MODELS: (A) WILL MEET YOUR REQUIREMENTS; (B) WILL BE AVAILABLE ON AN UNINTERRUPTED, TIMELY, SECURE, OR ERROR-FREE BASIS; OR (C) WILL BE ACCURATE, RELIABLE, FREE OF VIRUSES OR OTHER HARMFUL CODE, COMPLETE, LEGAL, OR SAFE.

TO THE FULLEST EXTENT PERMISSIBLE BY THE APPLICABLE LAW, WE HEREBY DISCLAIM ALL LIABILITY FOR PRODUCT DEFECT OR FAILURE, CLAIMS THAT ARE DUE TO NORMAL WEAR, PRODUCT MISUSE, ABUSE, PRODUCT MODIFICATION, IMPROPER PRODUCT SELECTION, NON-COMPLIANCE WITH ANY CODES, OR MISAPPROPRIATION.

TO THE FULLEST EXTENT PERMISSIBLE BY THE APPLICABLE LAW, WE HEREBY DISCLAIM ANY AND ALL RESPONSIBILITY, RISK, LIABILITY AND DAMAGES ARISING OUT OF DEATH OR PERSONAL INJURY RESULTING FROM ASSEMBLY OR OPERATION OF OUR PRODUCTS.

AIRWOLF 3D ASSUMES NO RESPONSIBILITY, NOR WILL BE LIABLE, FOR ANY DAMAGES TO, OR ANY VIRUSES OR MALWARE THAT MAY INFECT YOUR COMPUTER, TELECOMMUNICATION EQUIPMENT, OR OTHER PROPERTY CAUSED BY OR ARISING FROM YOUR ACCESS TO, USE OF, OR BROWSING THIS WEBSITE, OR YOUR DOWNLOADING OF ANY INFORMATION OR MATERIALS FROM THIS WEBSITE.

**Limitation on Liability.** IN NO EVENT SHALL AIRWOLF 3D (AND OUR SUPPLIERS) BE LIABLE TO YOU OR ANY THIRD PARTY FOR ANY LOST PROFIT OR ANY INDIRECT, CONSEQUENTIAL, EXEMPLARY, INCIDENTAL, SPECIAL OR PUNITIVE DAMAGES ARISING FROM OR RELATING TO THESE TERMS OF USE, EVEN IF WE HAVE BEEN ADVISED OF THE POSSIBILITY OF SUCH DAMAGES. ACCESS TO, AND USE OF, THE MODELS ARE AT YOUR OWN DISCRETION AND RISK, AND YOU WILL BE SOLELY RESPONSIBLE FOR ANY DAMAGE TO YOUR COMPUTER SYSTEM OR LOSS OF DATA RESULTING THEREFROM.

NOTWITHSTANDING ANYTHING TO THE CONTRARY CONTAINED HEREIN, OUR LIABILITY TO YOU FOR ANY DAMAGES ARISING FROM OR RELATED TO THESE TERMS OF USE (FOR ANY CAUSE WHATSOEVER AND REGARDLESS OF THE FORM OF THE ACTION), WILL AT ALL TIMES BE LIMITED TO THE GREATER OF (A) FIFTY US DOLLARS (\$50); OR (B) AMOUNTS YOU’VE PAID COMPANY IN THE PRIOR 12 MONTHS (IF ANY). THE EXISTENCE OF MORE THAN ONE CLAIM WILL NOT ENLARGE THIS LIMIT. YOU AGREE THAT OUR SUPPLIERS WILL HAVE NO LIABILITY OF ANY KIND ARISING FROM OR RELATING TO THESE TERMS OF USE.

SOME JURISDICTIONS DO NOT ALLOW THE LIMITATION OR EXCLUSION OF LIABILITY FOR INCIDENTAL OR CONSEQUENTIAL DAMAGES, SO THE ABOVE LIMITATION OR EXCLUSION MAY NOT APPLY TO YOU.

# FILAMENT GUIDE

Known for the ability to print in a wide range of thermoplastics, **Airwolf 3D** has spent countless hours perfecting the printing process from **PLA** and **ABS**, up to high-grade engineering materials like **polycarbonate**, **polyurethane** and **nylon**.

## BASIC MATERIALS

## Advanced Materials

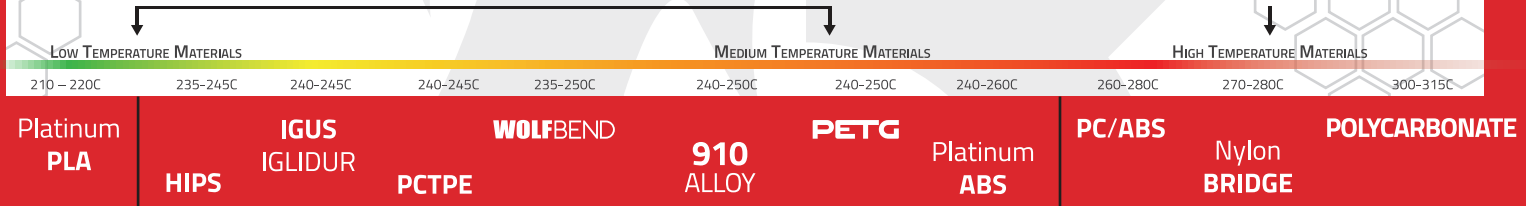

## MATERIAL CHARACTERISTICS

HIGH RIGIDITY	DISOLVES IN LIMONENE	SELF-LUBRICATING	VERY DURABLE	VERY FLEXIBLE	DURABLE	DURABLE	MEDIUM STRENGTH	HIGH STRENGTH	HIGH STRENGTH	HIGH RIGIDITY
PRONE TO FRACTURE	BRIGHT COLOR	ABRASION RESISTANT	IMPACT RESISTANT	LOW MODULUS OF ELASTICITY	HYDROSCOPIC	EXCELLENT SURFACE FINISH	GREAT DETAIL	GREAT DETAIL	SEMI-FLEXIBLE	HIGH HARDNESS
LOW STRENGTH	HIGH STRENGTH	HIGH STRENGTH	SEMI-FLEXIBLE	EXTREMELY DURABLE	CAN BE DYED	REPELLS LIQUID	CAN BE PAINTED	CAN BE PAINTED	CAN BE DYED	EXTREMELY TOUGH

## OPTIMAL PRINT TEMPERATURES

HOTEND: 215-220 BED: 60-70	HOTEND: 240 BED: 120	HOTEND: 240 BED: 120	HOTEND: 245 BED: 80	HOTEND: 240 BED: 60-80	HOTEND: 245-250 BED: 80	HOTEND: 240 BED: 80	HOTEND: 240-250 BED: 110-120	HOTEND: 285 BED: 130	HOTEND: 285 BED: 80	HOTEND: 300-310 BED: 135-145
-------------------------------	-------------------------	-------------------------	------------------------	---------------------------	----------------------------	------------------------	---------------------------------	-------------------------	------------------------	---------------------------------

## BED ADHESION METHOD

WOLFBITE NANO	WOLFBITE	WOLFBITE	WOLFBITE NITRO	WOLFBITE	WOLFBITE NITRO	WOLFBITE	WOLFBITE	WOLFBITE MEGA	WOLFBITE NITRO	WOLFBITE MEGA
---------------	----------	----------	----------------	----------	----------------	----------	----------	---------------	----------------	---------------

# REPLACEMENT PARTS/ACCESSORIES ORDER REPLACEMENT PARTS AND ACCESSORIES FROM [www.AIRWOLF3D.com](http://www.AIRWOLF3D.com)

From Wolfbite bed adhesion solutions to glass build plates, Airwolf 3D has you covered. Check out our bundle deals to save today!



**AXIOM FLEX-RESISTANT GLASS PLATE**  
Heavy duty Flex-Resistant Glass for AXIOM series 3D printers.



**BRASS CLEANING BRUSH**  
Cleans the nozzle for proper auto-leveling procedure.



**AXIOM ABS START-UP BUNDLE**  
Save money and get everything you need to print ABS on the AXIOM!



**AXIOM DUAL DD UPGRADE**  
Upgrade your AXIOM 3D Printer to a Dual Direct Drive Extruder.



**WOLFBIITE** for ABS, PETG, TPE, and TPU.  
Helps parts stick to the bed.



**WOLFBIITE NANO** for PLA.  
Helps parts stick to the bed.



**WOLFBIITE MEGA** for Polycarbonate and PC/ABS. Helps parts stick to the bed.



**WOLFBIITE NITRO** for Nylon.  
Helps parts stick to the bed.



**WOLFBIITE NITRO** for Nylon.  
Helps parts stick to the bed.

# FILAMENT



PLATINUM  
SERIES **ABS**



## PLATINUM ABS

Strong, durable, and easy to print.



PLATINUM  
SERIES **PLA**



## PLATINUM PLA

Bright colors, easy to print, biodegradable.

**PC ABS**  
PROFESSIONAL  
3D PRINTING  
FILAMENT

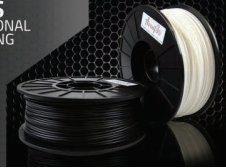

## PC ABS

Combination of ABS and PC. Very strong.

**POLYCARBONATE**  
3D PRINTING FILAMENT



## POLYCARBONATE

Extremely strong and resilient. Excellent layer bonding.



**BRIDGE**  
Nylon Filament



## BRIDGE NYLON

Low warping, strong and easy to print. Can be dyed with fabric dye.

**WOLFBEND**  
FLEXIBLE POLYURETHANE

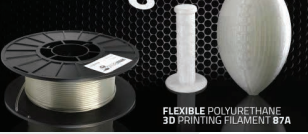

## WOLFBEND TPU

Pure polyurethane. Flexible and easy to print.



igidur® I180-PF  
Tribo-Filament



## IGLIDUR 180-PF

Self-lubricating filament. 60x more abrasion-resistant than ABS filament.



## HIPS

Great for printing high-detailed models. Similar to ABS.

**NYLON 680**



## NYLON 680

Mid-temperature nylon which is FDA approved.



**PCTPE**  
Plasticized  
Copolyamide

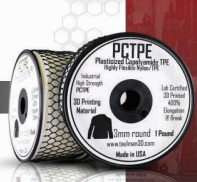

## PCTPE

Flexible Nylon/TPE combination. Extremely strong yet flexible. Can be dyed with fabric dye. Great for RC car parts!

**PETG**  
Copolyester



## PETG

Extremely durable filament. Produces excellent finish and surface quality and repels liquid. Semi-translucent.

**910 ALLOY**



## 910 ALLOY

Mid-temperature nylon that is easy to print with great strength properties.

Airwolf 3D printers can run many different types of materials. These include filaments that are not manufactured by Airwolf 3D. We provide settings for materials that we have tested in-house, and will continue to provide settings for new materials as they come out. We will continue to expand our material product line as we test and manufacture new and exciting filaments.

We do not recommend using materials from unknown suppliers. These materials are sometimes of poor quality and inconsistent in diameter. Airwolf 3D will not take responsibility for problems due to using poor quality filament. It is highly suggested that you find a material supplied by Airwolf 3D to meet your project needs.

# AXIOM 3D PRINTER

FRONT VIEW:

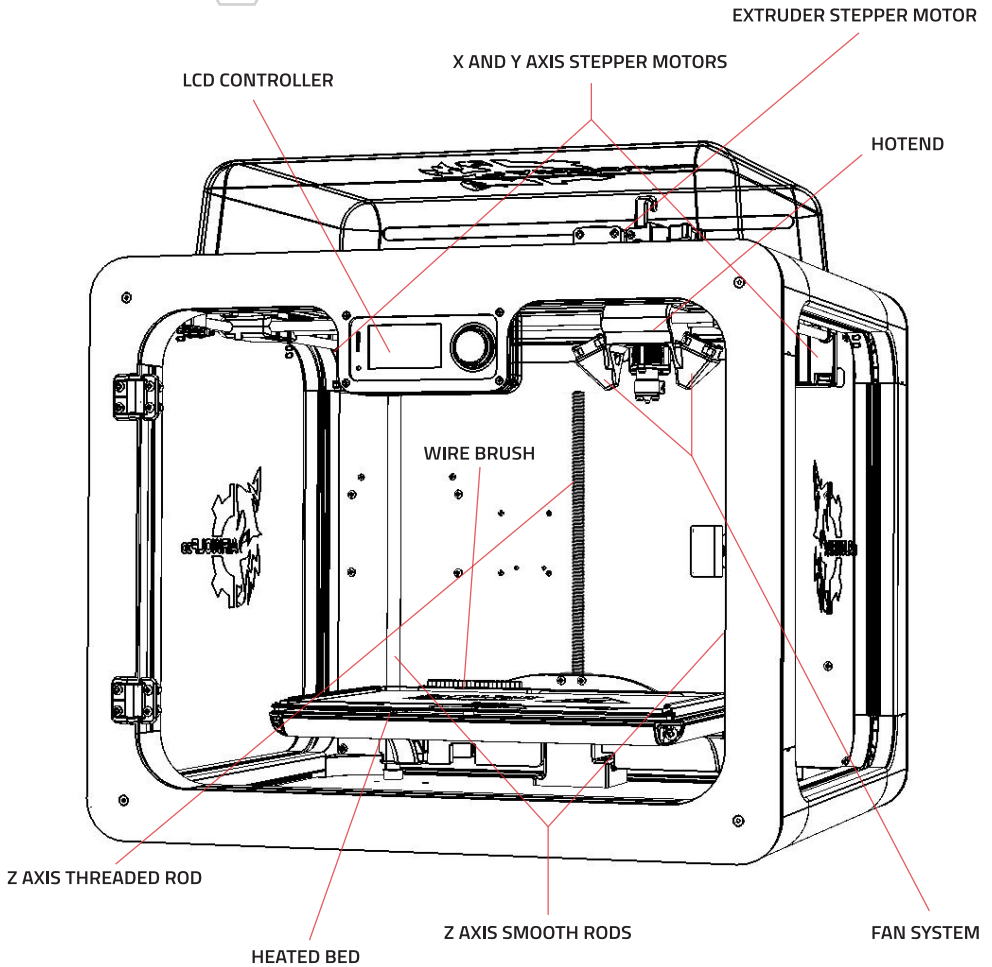

# AXIOM 3D PRINTER

BACK VIEW:

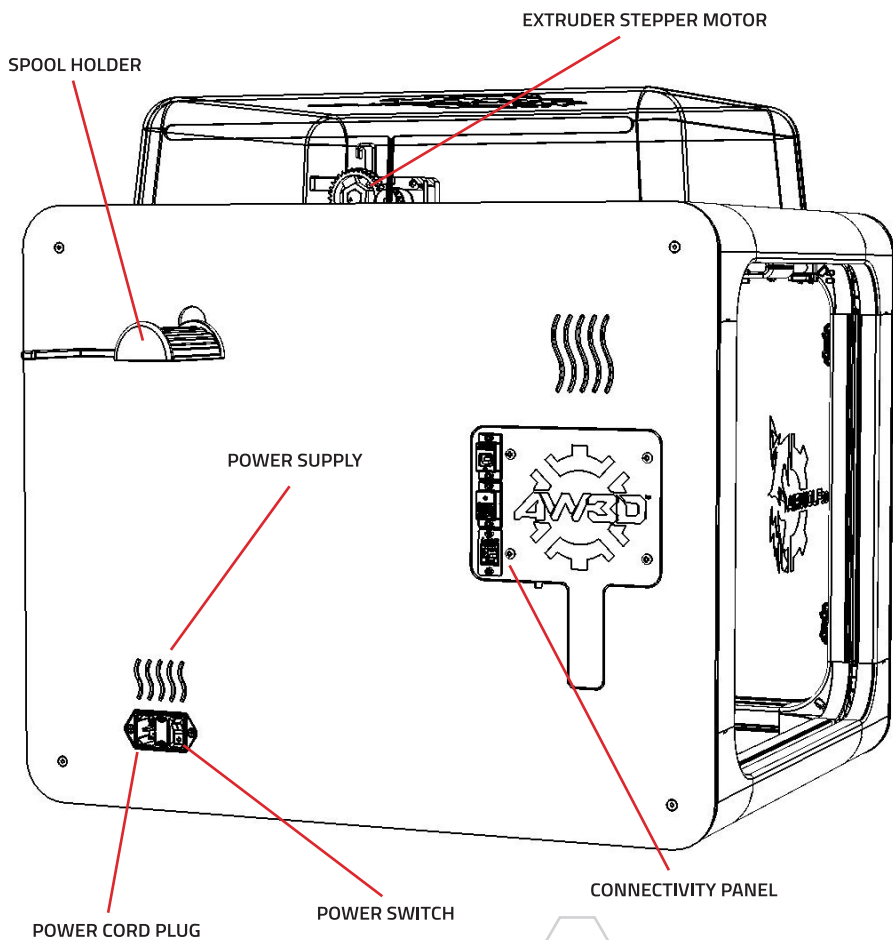



Phone: **949.478.2933**  
130 McCormick Ave. Suite 105,  
Costa Mesa, CA 92626



[www.airwolf3d.com](http://www.airwolf3d.com)

